

# AVANDA 212A

AVANDA 212A is a dual 12" three-way active DSP controlled line array loudspeaker. Designed for medium to large-scale sound reinforcement applications and mid-to-high-end fixed installations, it provides a high quality and powerful sound, meeting the requirements of any sound reinforcement application, indoors or outdoors.

The AVANDA 212A achieves a narrow vertical coverage in the high frequency range through the innovative ARROWHEAD™ waveguide technology, providing a clearer sound performance. The 90° horn provides a precise horizontal coverage and ensures that the system delivers an even and smooth sound.

CNC machined birch plywood cabinet, coated with polyurea, is waterproof, wear and high temperature resistant.

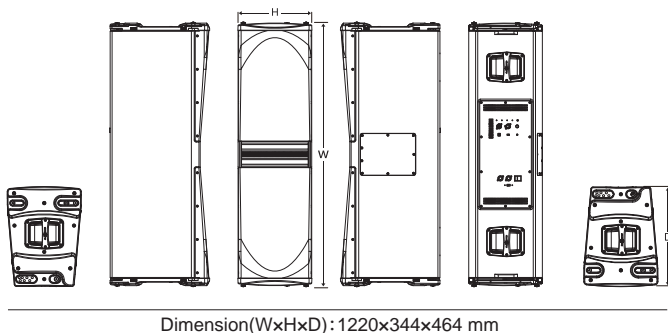
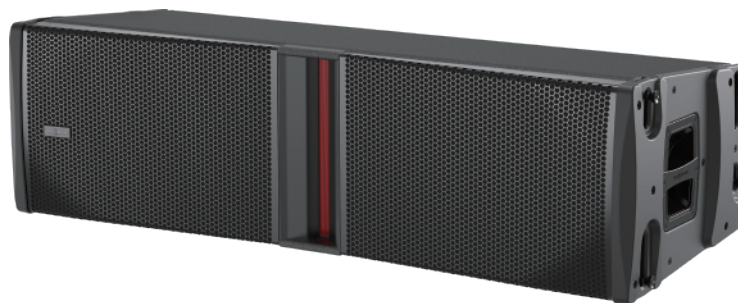

## Key Features

- **BrainCore™ Integration:** Seamless implementation of BrainCore™ technology for optimized system performance and supreme sonic fidelity.
- **ARROWHEAD™ Waveguide:** Advanced waveguide technology provides precise high-frequency directivity and enhanced clarity.
- **High-End Digital Processing:** State-of-the-art DSP featuring a 96kHz sampling frequency and FIR filtering for superior signal accuracy.
- **Efficient Class D Amplification:** High-output, integrated Class D amplifier delivers consistent power with maximum efficiency.
- **Versatile Performance Presets:** Three factory-optimized presets for quick and reliable setup in various acoustic environments.
- **Intelligent Power Management:** Automatic "sleep mode" activates after 45 minutes of signal inactivity to conserve energy.
- **Customized Transducers:** Precision-engineered drivers designed specifically to maximize the system's acoustic potential.
- **Thermal Protection:** Advanced temperature control system ensures stable operation and long-term reliability during demanding use.
- **Pro-Grade Construction:** CNC-machined birch plywood cabinet with a compact, optimized design for ease of deployment.
- **Rugged Polyurea Finish:** Ultra-durable, waterproof, and heat-resistant polyurea coating provides superior protection against wear and environmental factors.

## Specification

Frequency Response(-10dB)	60Hz-20kHz
Maximum Calculated SPL/1M(Continuous/Peak)	136dB/142dB
Horizontal Coverage	90°
Vertical Coverage	Splay angle dependent
HF	Customized Neodymium driver, 2x3"voice coil, 1.4"exit
MF	Customized 4x6" driver, 1.75"voice coil
LF	Customized 2x12" driver, 3"voice coil
DSP	
Processor	96kHz signal sampling frequency, FIR filtering
Presets	4 Units,8 Units,12 Units
AMPLIFIER	
Amplifier Circuitry	Class D
Power(RMS standards)	2600W
Peak Power	5200W
Frequency Response (1W 8Ω 2ch)	20Hz-20kHz(±0.5dB)
Intermodulation Distortion	< 0.05%
Total Harmonic Distortion	< 0.05%
Cooling System	Cooling with fans,air convection
Protection	DC protection, short circuit protection, overheat protection, input overload protection, output overload protection, soft startup protection, overvoltage protection, undervoltage protection
Output/Input	
Signal Input	Female XLR
Signal Output	Male XLR
Power Input	Power connector
Power Output	Power connector
AC Power Operating Range	100V-130V~ or 220V-240V~(±10%,50/60Hz)
Power consumption (1/8 output power)	300W
Cabinet	
Cabinet Material	Multilayer baltic birch plywood
Angle Adjustment	0°, 1°, 2°, 4°, 6°, 8°, 10°
Coating	Durable Polyurea Coating
Cabinet Color	Black is the default color. Contact Audiocenter for customization
Grille	Iron mesh
Handles	2 side,2 rear
Speaker Dimension(WxHxD)	1220x344x464mm
Carton Dimensions (WxHxD)	1322x568x443mm
Net Weight	67.0 kg
Shipping Weight	70.0 kg



## Frequency Response Graphs

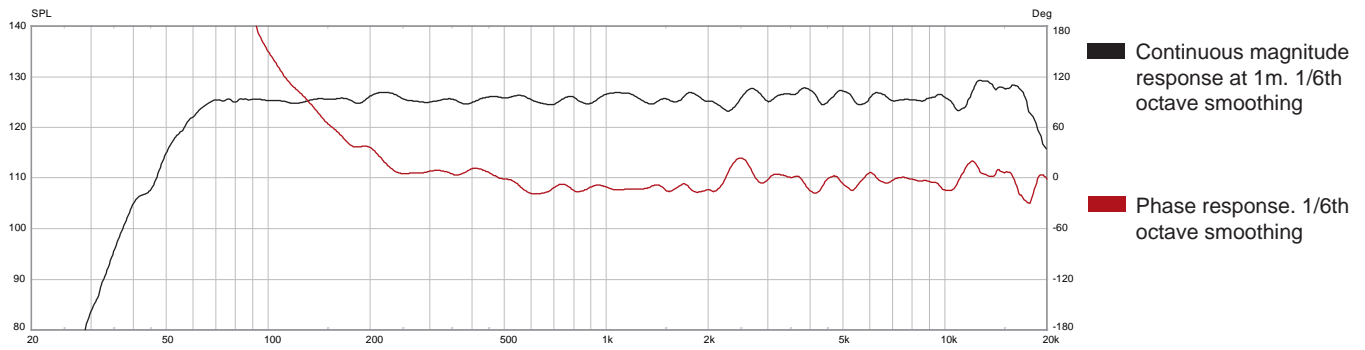

## Normalized Isobar Plot

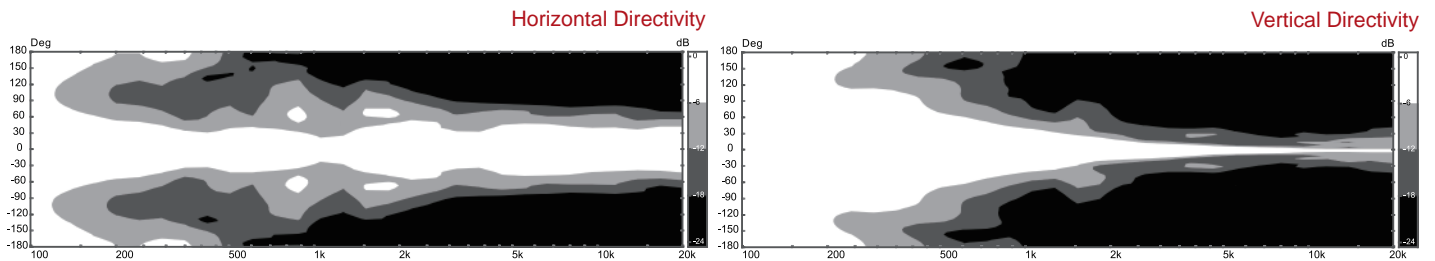

## Internal Structure

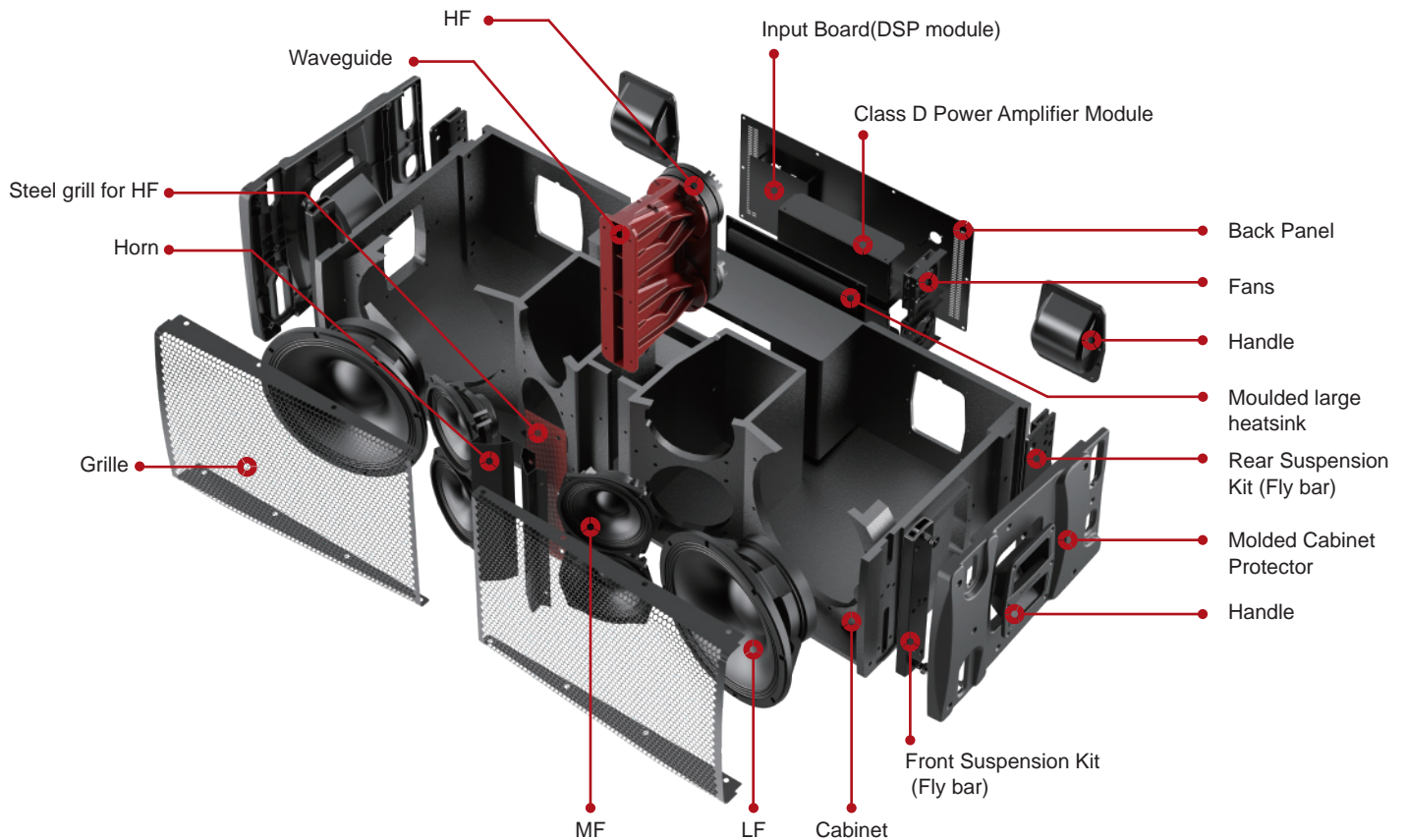

## Accessories

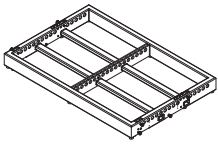

**FGF-AVANDA 212A/210A/28A**  
Flying and Ground Stack Frame

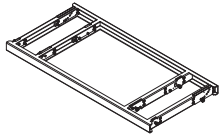

**CF-AV212A-210A**  
**CF-AV212A-28A**  
**CF-AV210A-28A**  
Coupling Frame

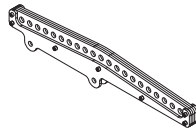

**AVANDA 212A**  
extension bar

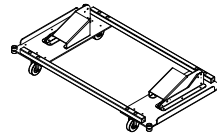

**AVANDA 212A/210A/28A**  
dolly + protective cover  
(for 4 cabinets)

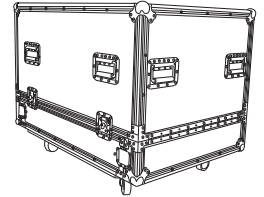

**AVANDA 212A/210A/28A Flightcase**  
For 2 cabinets, with 100mm wheels

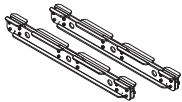

**AVANDA 218A**  
Flying frame set



**AVANDA 218A Hanging**  
side-brackets kit

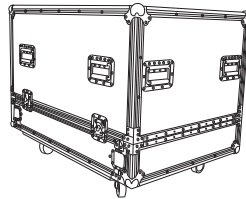

**AVANDA 218A Flightcase**  
For 1 cabinet, with 100mm wheels

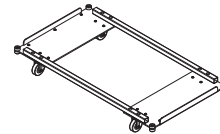

**AVANDA 218A dolly +**  
protective cover  
(for 3 cabinets)

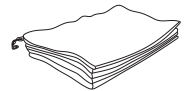

**Rain bag**  
(customized)

## Installations

