

AUDIOCENTER

Dynamic Audio Solutions

BrainCore™

Technology Inside

User's Manual

AVANDA SERIES

Active DSP-controlled Line Source Array Speaker



Contents

Product Introduction	02
Safety precautions	02
Technical Features	04
Product Appearance	06
Back panel control and functions	08
Suspending the AVANDA series Loudspeakers	10
Cable Connections	11
Connect Loop-thru Power Cables	12
Application Examples	14
Product Dimensions	16
Technical Specification	20
Trouble Shooting	21

◆ Product Introduction

Thank you for purchasing AVANDA series Active DSP-controlled Line Source Array Speaker system from Audiocenter. They have integrated technologies of switch mode power supply, big power digital amplifier and DSP control as well as speakers made of new materials. It is the result of years of R&D effort. We hope that you can use with pleasure just as how we designed it. Please finish reading the manual before usage, to make sure the best performance of AVANDA Series.

Please keep the manual for future reference.

◆ Safety precautions

When you set up, install and use the AVANDA, please follow the following safety measures strictly:

- There can be danger in any step during hanging installation. Everyone should pay attention to personal safety. All purchasers of Audiocenter should be professional people qualified to conduct the work related to such equipments.
- We strongly suggest the users pay full attention to local rules, regulations and laws.
- Installers have the responsibility to make sure the speaker installations are subject to local rules, regulations, and laws.
- If any danger or defect is detected, measures should be taken immediately to correct it. In touring application, please choose the installation hardware and occasion that can sustain the weight of the equipments.
- Please do not try to hang speakers over the design standard.
- When connecting the cables of the products, please use cable tie to fix the cables, to avoid actors, workers, and audience falling on the wire or brackets and affecting the speaker system.
- Please do not place the speakers near equipments sensitive to magnet fields, such as CRT displayer, TV or data saving materials.
- Please do not place the power cable near heating source. Do not over bend or damage the power cables. Do not place heavy things on it. Please do not place the cables that may be pressed or cause stumbling.
- Only the specified rated voltage should be used for this product. Please refer to the back panel of the product for the specified voltage.
- Only the supplied power cable or plug should be used. (If you need to use the product in a place different from the purchase place, please consult your local Audiocenter distributor.)
- Please check the power cable or plug regularly.
- Please make sure to connect to proper power socket with protection grounding connection.
- Wrong grounding may cause short circuits.
- The product inside does not include any component that can be repaired by users. In case of abnormal operation, please stop using immediately, and contact qualified Audiocenter maintenance worker to repair.
- Please do not use the product in the rain, or near water, or in humid environment, to avoid liquid spilling to any opening.

- When any of the following situations occurs, please cut the power immediately, and pull out the power plug from the socket, and ask qualified Audiocenter maintenance worker to repair.
 - Wear or damage of the power cable or plug.
 - Abnormal smell or smoking
 - Some substance falls into the product
 - Sound stops suddenly when using the product.
- If the product falls or damages, please turn off the power switch immediately. Pull out the power plug from the socket, and ask qualified Audiocenter maintenance worker to repair.
- When pulling out the power plug from the power socket or the product, please make sure to grab the plug instead of the power cable. Pulling the power cable directly may cause damage.
- If the product is not used for long time, or there is thunder storm, please pull out the plug from the socket.
- Please do not place the product in any uneven position. Otherwise, it may cause falling off suddenly.
- If the product is not fixed safely, please do not place it in a position that may cause easy falling.
- Please do not block the air hole. The product has air hole at the back to avoid internal temperature too high. Bad ventilation may cause damage to the product or even fire.
- Please do not hang or install any other component to the handle of the speaker. It may cause damage or injure.
- Please do not press the back panel of the product to the wall. Otherwise the plug may touch the wall and separate from the cable, and cause short circuits, malfunction, or even fire.
- Before connecting the product to other equipment, please turn off the power switch of all equipments. Before turning on or off the power switch of all equipments, please turn down the volume to the minimum.
- Please do not use the product in a very high or uncomfortable volume. Otherwise, it may cause permanent damage to your ear.
- In case of sound distortion, please do not use the product. To Continue using the product in such status may cause fire.
- Using mobile phones near the speaker may cause noise. In case of noise, please use the mobile phone far from the speaker.
- If you need service, please contact Audiocenter service center, agent, or distributor in your area.

⚠ In order to avoid to cause you or others body injury and loss on equipment or property, please make sure to follow above basic items.

Package accessories:

- PowerCon loop cable
- User's manual
- XLR audio loop cable
- Quality certificate

Please check above items carefully. If any questions, please advise Audiocenter representative, dealers, distributors, or contact by email box: support@ac-pro.net.

Optional accessories:

- Frame for flying and ground stacking
- Flightcase
- Rain bag
- Dolly

◆ Technical Features

AVANDA 210A

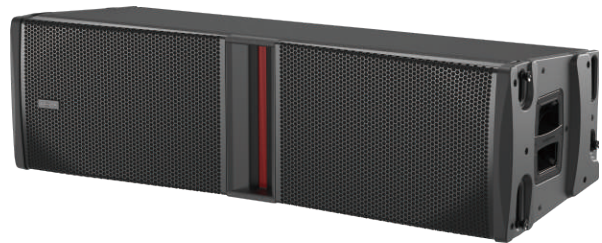

AVANDA 212A



AVANDA 28A

● **Features:**

- 1.The innovative BrainCore™ technology and built-in powerful DSP processor improve the performance of the speaker. With Cort™ correction technology and Limita™ processing technology, the system works with safety and reliability and achieves supreme performance.
- 2.FIR filtering enhances the audio's attack,ensuring a dynamic and impactful sound experience. The linear phase response preserves the original transient characteristics of the audio signal, resulting in a sharper, more defined attack.
- 3.AVANDA Series is built with 3 different presets. Users can choose different presets according to the number of units via the switch on the back panel.
- 4.The global unique ARROWHEAD™ waveguide technology is developed by using the most advanced and complex Boundary Element Method (BEM).
- 5.The power amplifier module and DSP module have been designed by Audiocenter's R&D team in Germany and manufactured according to German engineering standards.The system operates stably and efficiently,ensuring high-quality audio output.
- 6.The cabinet is built according to a scientifically rigorous acoustic structure, using high-quality birch plywood and molded parts to minimize resonance. The cabinet is compact, sturdy and has a professional and stylish appearance.
- 7.Moulded large heatsink improves cooling , resulting in higher reliability.
- 8.The polyurea coating provides waterproof, wear resistance, impact resistance and aging resistance characteristics.
- 9.To save power, the system will enter into sleep mode automatically if without signal input for 45 mins.
- 10.Built-in flying hardware.
- 11.Latest driver technology and customized drivers ensure a clean sound and impressive dynamics.
- 12.EASE GLL file available.

◆ Product Appearance

AVANDA 28A

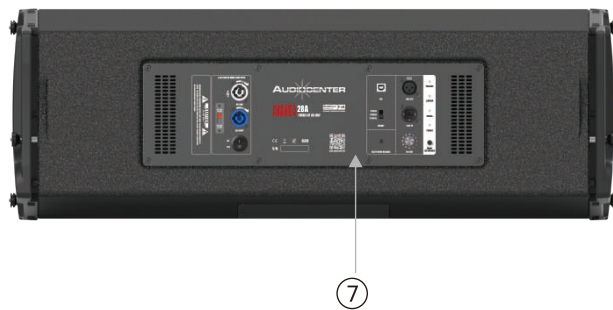
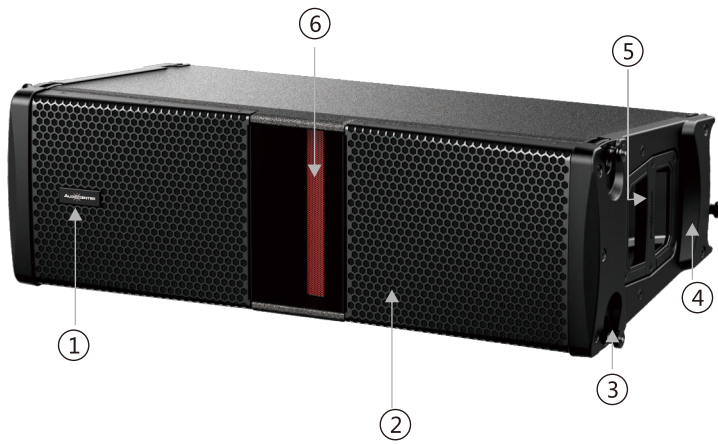

- 1. logo
- 2. Grill
- 3. Front built-in locking Accessories
- 4. Back built-in locking Accessories
- 5. Handle
- 6. Horn
- 7. Amplifier module

AVANDA 210A

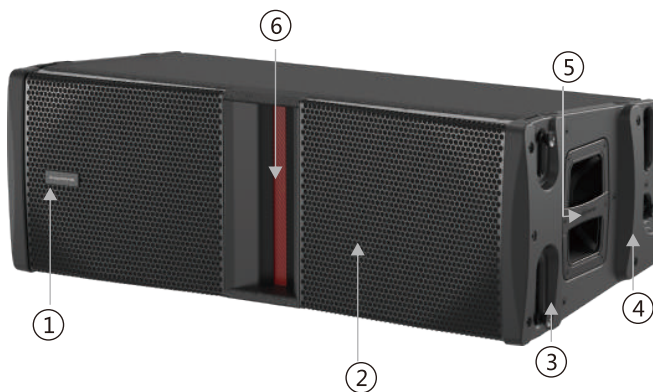

- 1. logo
- 2. Grill
- 3. Front built-in locking Accessories
- 4. Back built-in locking Accessories
- 5. Handle
- 6. Horn
- 7. Amplifier module

AVANDA 212A

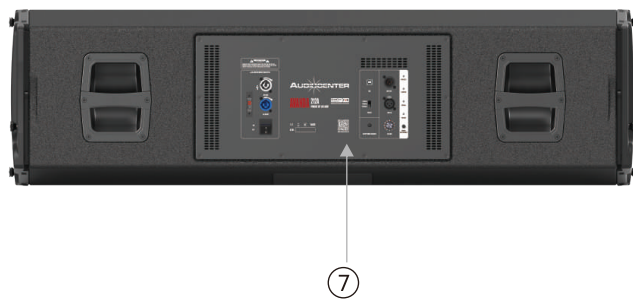
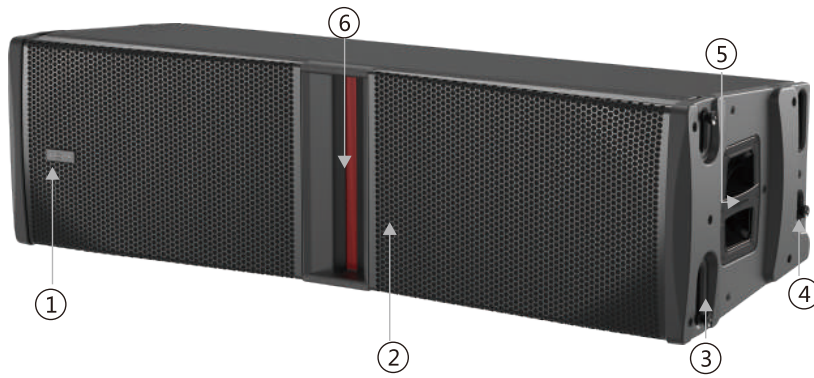

- 1. logo
- 2. Grill
- 3. Front built-in locking Accessories
- 4. Back built-in locking Accessories
- 5. Handle
- 6. Horn
- 7. Amplifier module

◆ Back panel control and function

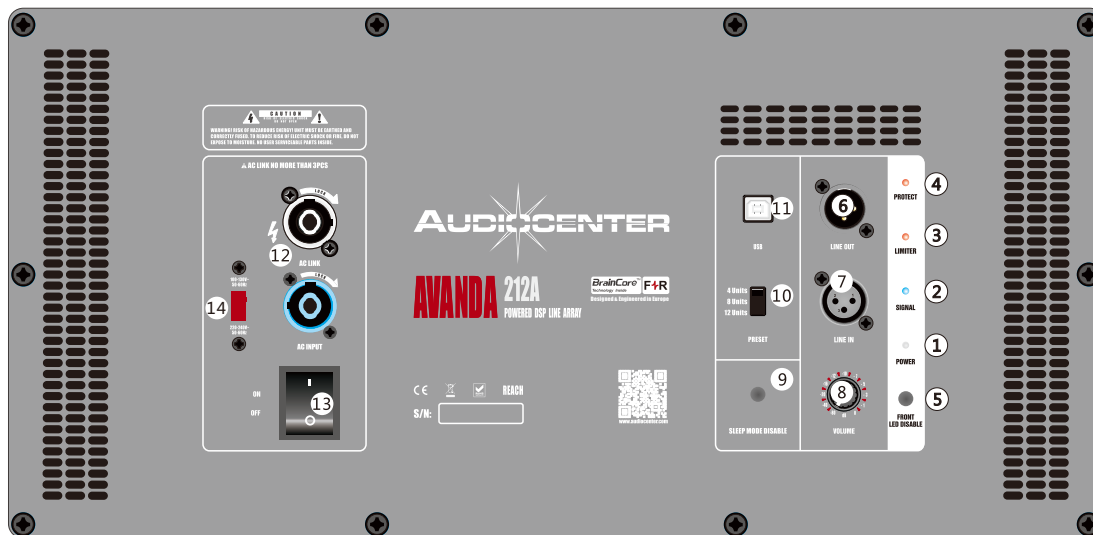

1 POWER Indicator:

When speaker connected to power, the LED is on.

2 SIGNAL Indicator:

When detecting channel has input signal, the LED is on.

3 LIMITER Indicator

The LED turns on when output limiter is activated. If the output voltage of the amplifier exceeds the maximum value, output limiter will be activated damping the output signal of the amplifier.

4 PROTECT Indicator

The light turns on if the amplifier is detected to be overheated. And the amplifier enters into the protection status.

5 FRONT LED button switch

The front panel LED indicator light won't illuminate when the switch is pressed down (this setting is recommended when the front panel LED indicator light is too bright).Upspring the button, the front panel LED indicator light on.

6 OUTPUTS SOCKET(LINE OUT)

Balanced XLR(Male), Parallel to(LINE IN),the signal in LINE OUT is equivalent with the signal inLINE IN. And the signal in LINE OUT XLR will without influence when set up the volume for speaker.

7 INPUTS SOCKET (LINE IN)

Balanced XLR input socket.

8 MASTER VOLUME control knob

Volume knob controls the input signal gain of Line In. This knob can adjust the sensitivity, so as to control the amount of signal sent to the power amplifier and then to the speaker.

9 SLEEP MODE DISABLE

Press to turn the sleep mode ON/OFF.

10 PRESET choosing button

For AVANDA series there are 3 presets available for the users choosing according to different sound performance needed in different applications. Users can choose the optimal sound performance via buttons.

11 USB terminal

Debug by factory (it is not open to the user).

12 POWER Connection

AVANDA Series has a loop-through power connection system. Power supply can be linked according to different situations, please see connect power switching to learn more.

13 AC INPUT Slot

Connect the cable to the slot. Connect the power wire to the device first and then connect the cable to the AC slot.

14 Voltage Selector

Sets the operating voltage for compatibility with the voltage supply in the country of use.

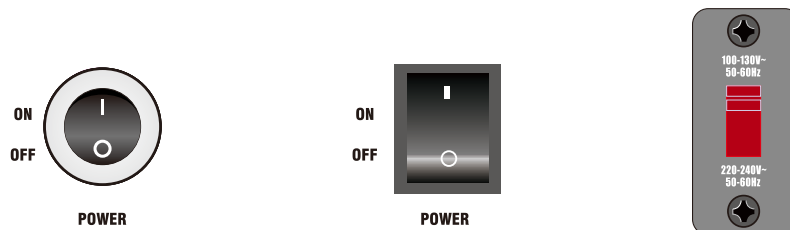

NOTE: The AVANDA employs a universal power supply, capable of operating the system with input AC power voltages ranging from 100-130V~ 50-60Hz and 220-240V~50-60Hz.Use only the power cable that is correct for your location.

◆ Suspending the AVANDA series Loudspeakers

⚠ WARNING! Read and follow these instructions carefully. If the loudspeakers are not suspended properly, they could fall causing personal injury and damage to the equipment.

Rules for Suspension

- Consult a professional mechanical or structural engineer licensed in the jurisdiction of the sound system installation, to review, verify, and approve all attachments to the building or structure.
- Employ the services of a certified, professional rigger for hoisting, positioning and attaching the equipment to the supporting structure.
- Correct use of all suspension hardware and components is imperative in sound system suspension and deployment.
- Always calculate suspended loads before lifting to make sure suspension components and hardware are used within their respective load limits.
- Consult local codes and regulations to fully understand the requirements for suspended loads in the venue in which you will suspend the equipment
- Use only the AVANDA series Array Frame for suspending the array.
- Be absolutely certain of the integrity of any structural member intended to support suspended loads. Hidden structural members can have hidden structural weakness.
- Before lifting, always inspect all components (pins, suspension brackets, bolts, nuts, fly belt, stainless steel shackle etc.) for cracks, wear, deformation, corrosion, missing, loose, or damaged parts that could reduce the strength of the assembly. Discard any worn, defective, or suspect parts and replace them with new appropriately load-rated parts.
- When a load is either moved or stopped, its static weight is magnified. Sudden movements can magnify the static weight several times. This magnification of static weight is called "shock loading". Shock loading poses a danger to equipment and workers. The effects of shock loading can be instantaneous, or may remain undetected unless the equipment is visually damaged.
- Proper preparation for shock loading requires careful planning and knowledge of equipment, suspension, and lifting practices.

Shock loading of equipment and structures is usually confined to lifting and installation, but natural forces (winds, earthquakes, and so on) can impose shock loads several times the static load. Because of this, structures and suspension equipment must be capable of supporting several times the weight of the suspended equipment

Maximum Suspended Load

The AVANDA components are safe engineered design.

The mechanical parts for AVANDA array system all use the finest stainless steel, completely consider of the safety. One side of array system can maximum set up 16pcs of AVANDA Series loudspeakers and this is make sure safe when use (Any questions, please contact the service centre or agency or dealer of Audiocenter at your area).

◆ Cable Connections

Making Audio connections

Figure 1 (Connection for balanced inputs), Figure 2 (Connection for unbalanced inputs)
 The soldering welding way to connect the frequency patch cable:

Balanced inputs:

Connect to the plug as shown.

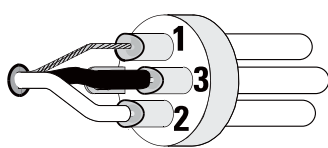

1-1

1=shield (ground)

3=negative (-)

2=positive (+)

Unbalanced Inputs:

Connect to the plug as shown.

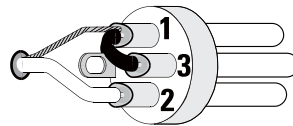

1-2

1=shield (ground)

3=jumper to pin 1

2=positive (+)

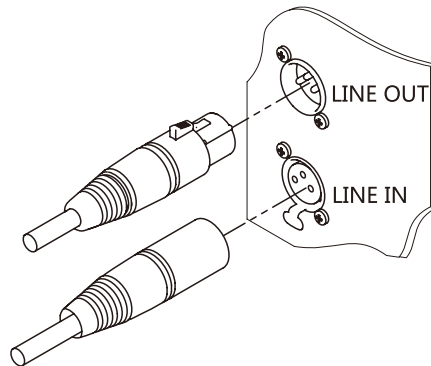

1-3

The loop-thru cables supplied in the package are designed for use in the array (Figure 3)

1. Connect the audio source (male XLR plug) to the LINE IN female XLR connector on the amplifier.
2. If you are using the audio loop-thru connections, connect the female end of an XLR Audio Loop-thru Cable (supplied) to the LINE OUT connector on the first amplifier in the loop-thru chain.
3. Connect the male end of the XLR Audio Loop-thru Cable to the LINE IN of the next loudspeaker amplifier in the loop-thru chain.
4. Continue this process until all the audio connections for the loudspeakers in the array are made.

System Power

For safety reasons, it is important to follow the proper power connection and disconnection sequence as addressed in this section.

Proper power on/off sequencing can help to prevent unexpected sounds from being produced by the system (pops, clicks, thumps). These sounds are unpleasant and can take away from the overall professionalism of the presentation. Always follow the rule that loudspeakers are “last on, first off”.

◆ Connect Loop-thru Power Cables

AVANDA features a loop-thru power connector system. Using four powerCON Loop-thru cables, and one AC powerCON Power Cord, you can power up to a maximum of five AVANDA Series loudspeakers on a single 16 amp/120V (8amp/240V) electrical circuit. The loop-thru connectors are color coded (blue = AC IN / white = AC LINK) and keyed differently to make sure the connections are correct.

⚠ WARNING! The amplifier POWER switches do not remove AC mains power from the loop-thru cables. If the AC mains is connected to AVANDA Series, electrical power is present on all connected loop-thru cables.

present on all connected loop-thru cables.

1. Make sure that all AC POWER (POWER) are off.
2. Make sure that the AC mains power cord is not connected. AC mains is the last power connection in the sequence.

⚠ WARNING! Do not connect more than five AVANDA Series loudspeakers together using the loop-thru power cables (four loop-thru cables, one AC power cord). If you are using loop-thru power cables, make all loop-thru connections prior to connecting to the AC mains.

1. Insert the white powerCON connector, on the loop-thru cable, fully into the white AC LINK connector on them amplifier.
2. Twist the powerCON connector clockwise until it locks in place.
3. Insert the blue powerCONconnector fully into the blue AC IN connector on the next amplifier to be powered.
4. Twist the powerCON connector clockwise until it locks in place.
5. Repeat until all of the loudspeakers (up to five loudspeakers, using four loop-thru cables) in the array are properly connected.
6. Insert the blue powerCON connector, on the AC power cord, fully into the blue AC IN connector on the first amplifier in the chain.
7. Twist the powerCON cable connector clockwise until it locks in place.
8. Plug the other end of the power cable into the appropriate AC mains power source.
9. You may now turn on the AC power switch(es) using the Power-On procedure in this document.

Power-on Sequence

1. Bring the output level control of the mixer (or other audio source) feeding your loudspeakers to its minimum position.
2. Turn on all source devices (CD players, mixers, instruments).
3. Push on the power switch (POWER) up to "T" to apply AC mains power to the first powered loudspeaker in the signal chain.
4. When the amplifier is turned on, the white POWER indicator LED/the blue SIGNAL Indicator LED/the red LIMIT indicator LED, and the red PROTECT indicator LED on the amplifier panel, illuminate. After a few seconds the red PROTECT indicator, the blue SIGNAL and the red LIMIT indicator go out, and the white POWER indicator LED illuminates.
5. Turn on the remainder of the AVANDA loudspeakers in the order in which they receive audio signal first to last.
6. The level controls on your mixer may now be brought up.

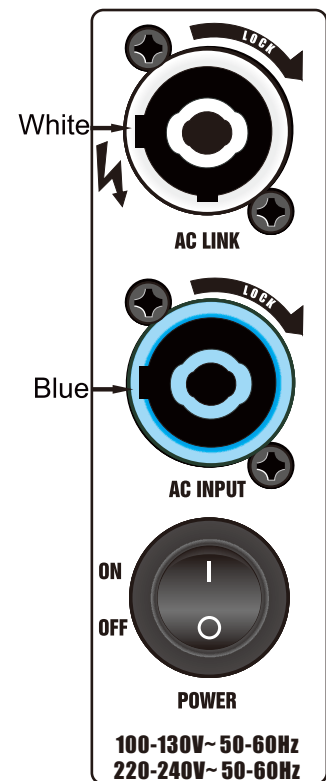

Power-off Sequence

1. Bring the output level control of the mixer (or other audio source) feeding your loudspeakers to its minimum position.
2. Turn the power switch (POWER) down to "0", turn off AVANDA, starting with the last loudspeaker in the signal chain.
3. Turn off the remainder of the AVANDA loudspeakers in reverse of the order in which they receive audio signal-last to first
4. Turn off all source devices.

Disconnect AC Mains

1. Bring the output level control of the mixer (or other audio source) feeding your loudspeakers to its minimum position.
2. Turn the power switch (POWER) down to "0", turn off AVANDA, starting with the last loudspeaker in the signal chain.
3. Turn off the remainder of the AVANDA loudspeakers in reverse of the order in which they receive audio signal-last to first.
4. Turn off all source devices.

● SLEEP function:

AVANDA Series are equipped with an automatic SLEEP function that saves power when not in use. If AVANDA Series input terminal does not have an audio signal for 45 minutes (or the volume is minimal), the device will be in SLEEP mode, and the indicator light in front of the speaker will change from blue (working) to red (SLEEP). When the device is in SLEEP mode, if an audio signal appears, the indicator light in front of the speaker will change from red (SLEEP mode) to blue (working mode). When the amplifier is in SLEEP mode, a small amount of current continues to flow in order to awaken the amplifier. It takes about 1 seconds to go from SLEEP to full operation without any sound.

◆ Application Examples



Notice 1: Before hanging up the line array, please make sure the loading capacity. The speaker assembly and hardware can not be overloaded. The maximum combination of the line array should be no more than 16PCS.

Notice 2: Make sure the speakers in the line array are aligned, otherwise, it means the pins are not well connected and it will make the speakers detach and thus cause damage of the assembly or injury to people.

Notice 3: While hanging up the line array, the speakers and assembly of it should be well-supported.

Notice 4: Under all circumstance, the connection between hanging frame and speakers or assembly should start from under part to the upper section.

● Connection between speaker assembly and hanging frame:

Before hanging up, the front and back connecting poles of AVANDA Series are locked. Please see the example: when rotating the assembly on the speaker upward, you should make sure the back connecting pole is aligning with the pole on the hanging frame, and then lock it with the pin.

Repeat the above process until all the speakers needed are firmly locked. After that, the line array is ready and you can hang it up.

Notice: Please make sure the speaker assembling pin are firmly locked with the hanging frame. Otherwise, if they didn't lock correctly, the speakers would probably detach and cause damaged to the speakers and injury to people.

● Hanging of the line array :

Notice 1: Before hanging up the line array, please consult professional construction or mechanical engineers with installation license, asking them to check, test or approve all the additional equipments on the building or construction. And you should ask the licensed professional assembling staffs to locate, hang up the line array to corresponding places.

● Dispatching of the line array:

Before dispatching the line array, please correctly prop up both side of it so as to lighten the stress that the heavy speakers had to its locking device, and thus separate the speakers from each other. Move down the front and back connecting pole and place it back to the speakers, and then lock it up with the pin. Please proceed the same process on the other side of the line array. Thus, all the speakers and assembly will be dispatched.

When connecting flying belt, shackle with the hanging frame, the different hole you connected to will engender different sloping angel of the line array.

● Application Examples

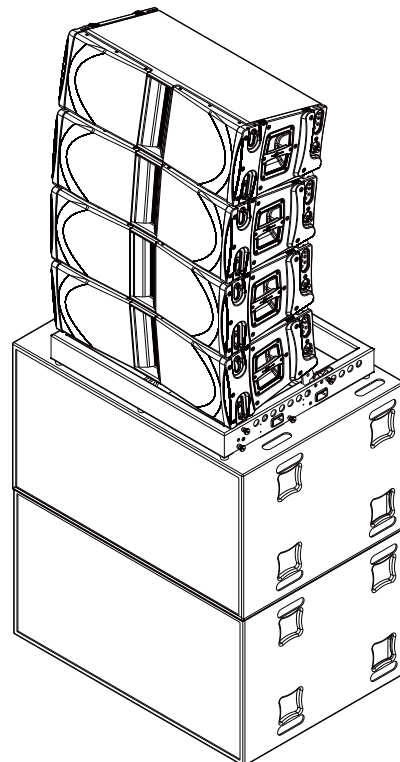
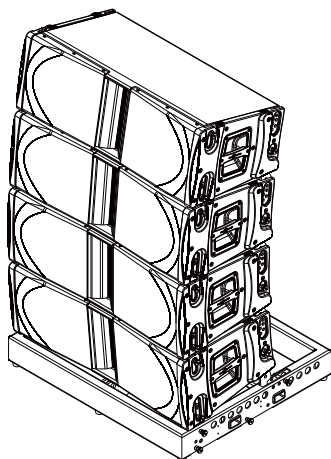
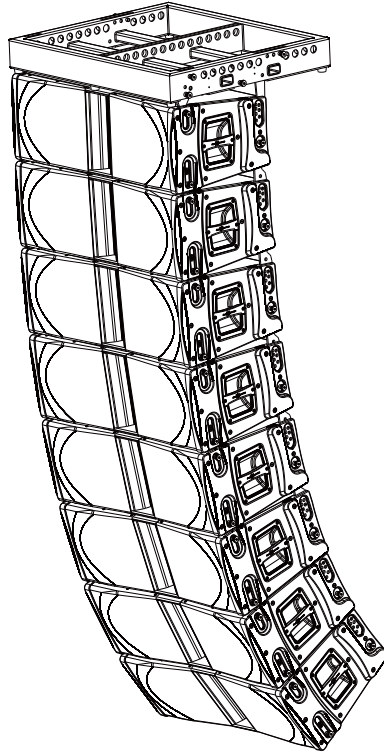

◆ Product Dimensions

- FGF-AVANDA28A

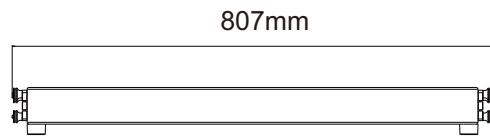
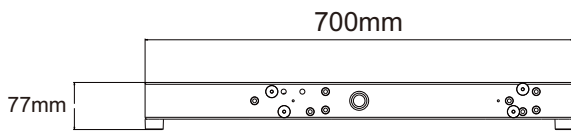
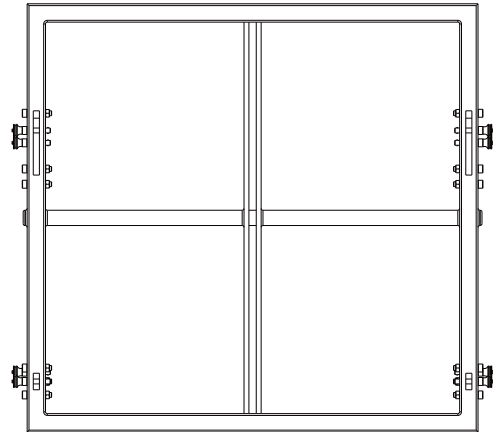
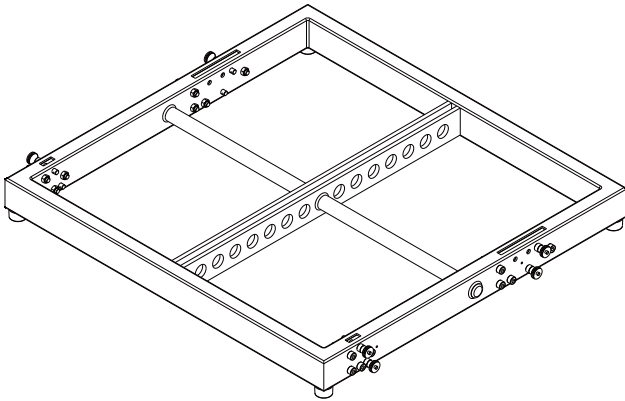

Dimension(WxHxD):807x77x700mm

- FGF-AVANDA210A

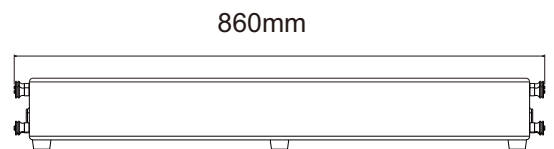
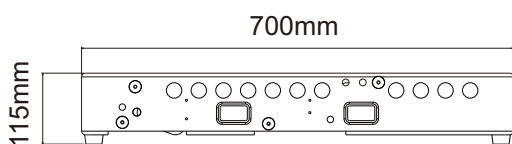
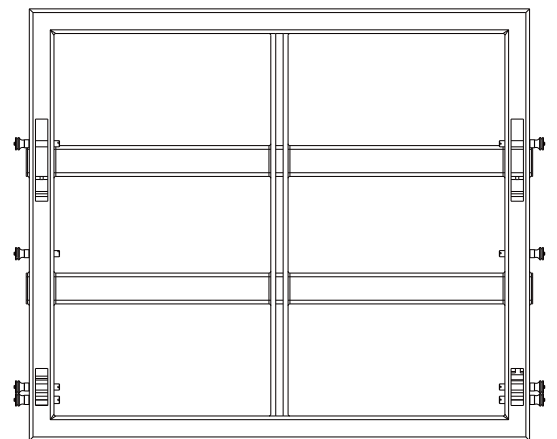
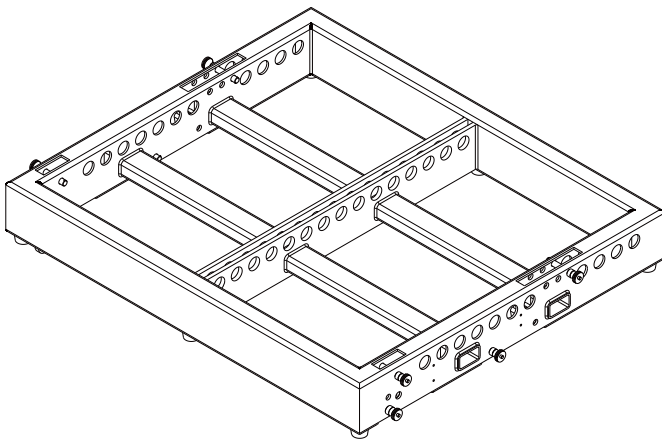

Dimension(WxHxD):860x115x700mm

● FGF-AVANDA212A

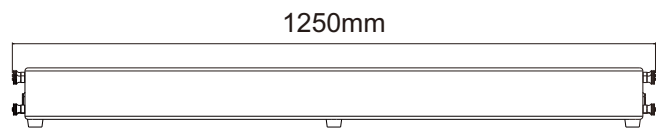
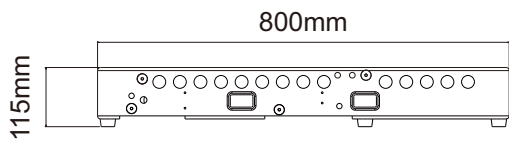
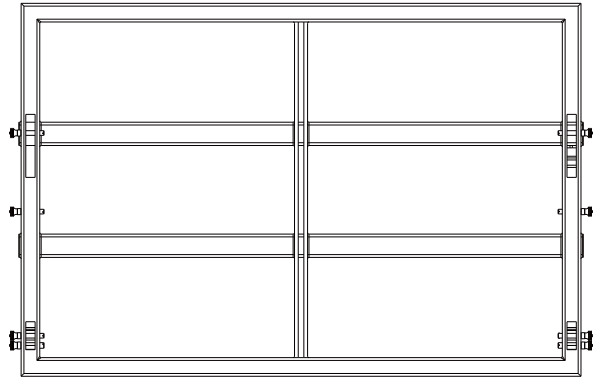
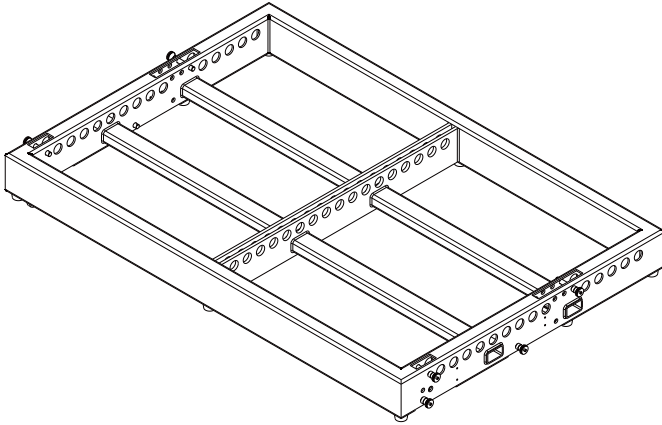

Dimension(WxHxD):1250x115x800mm

● AVANDA 28A

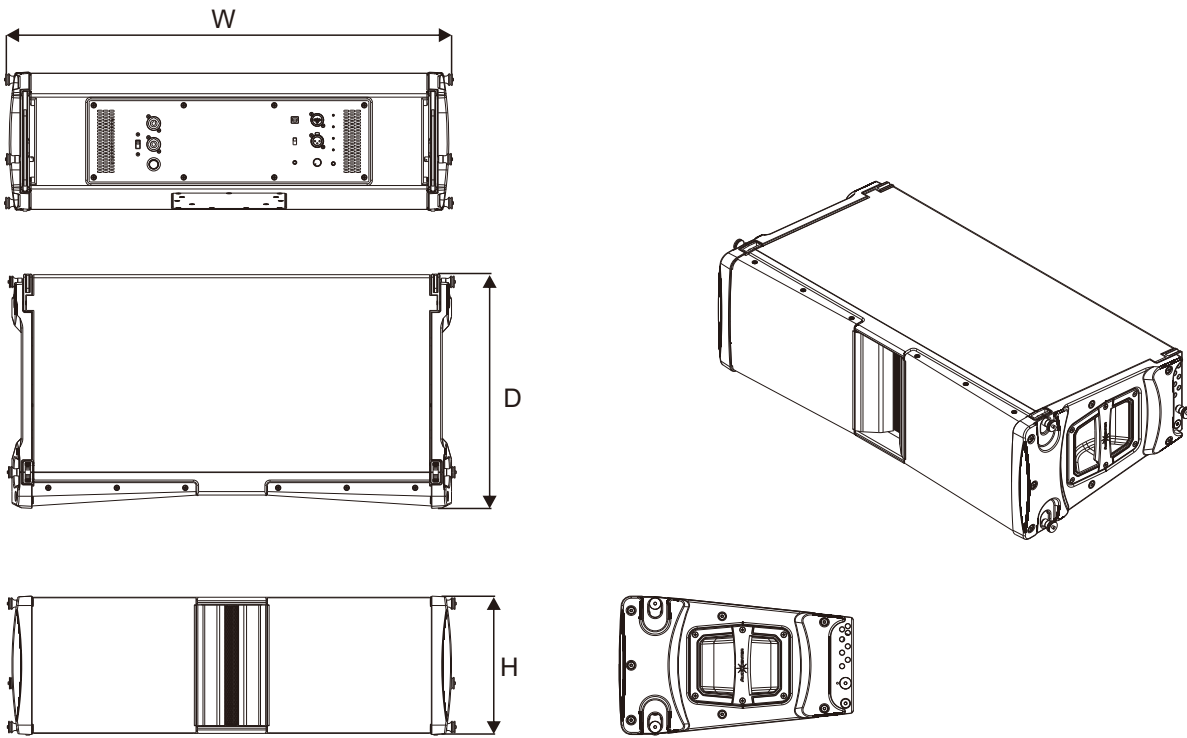

Dimension(WxHxD):774x240x406mm

● AVANDA 210A

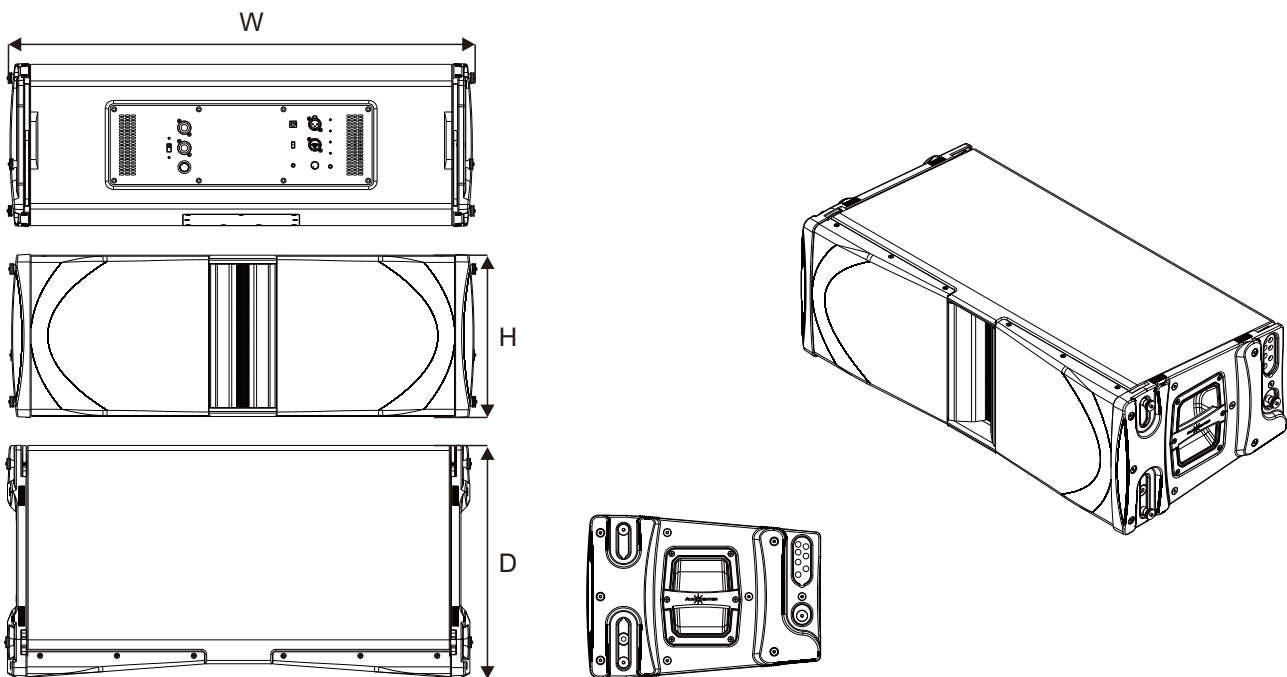

Dimension(WxHxD):830x293x420mm

● AVANDA 212A

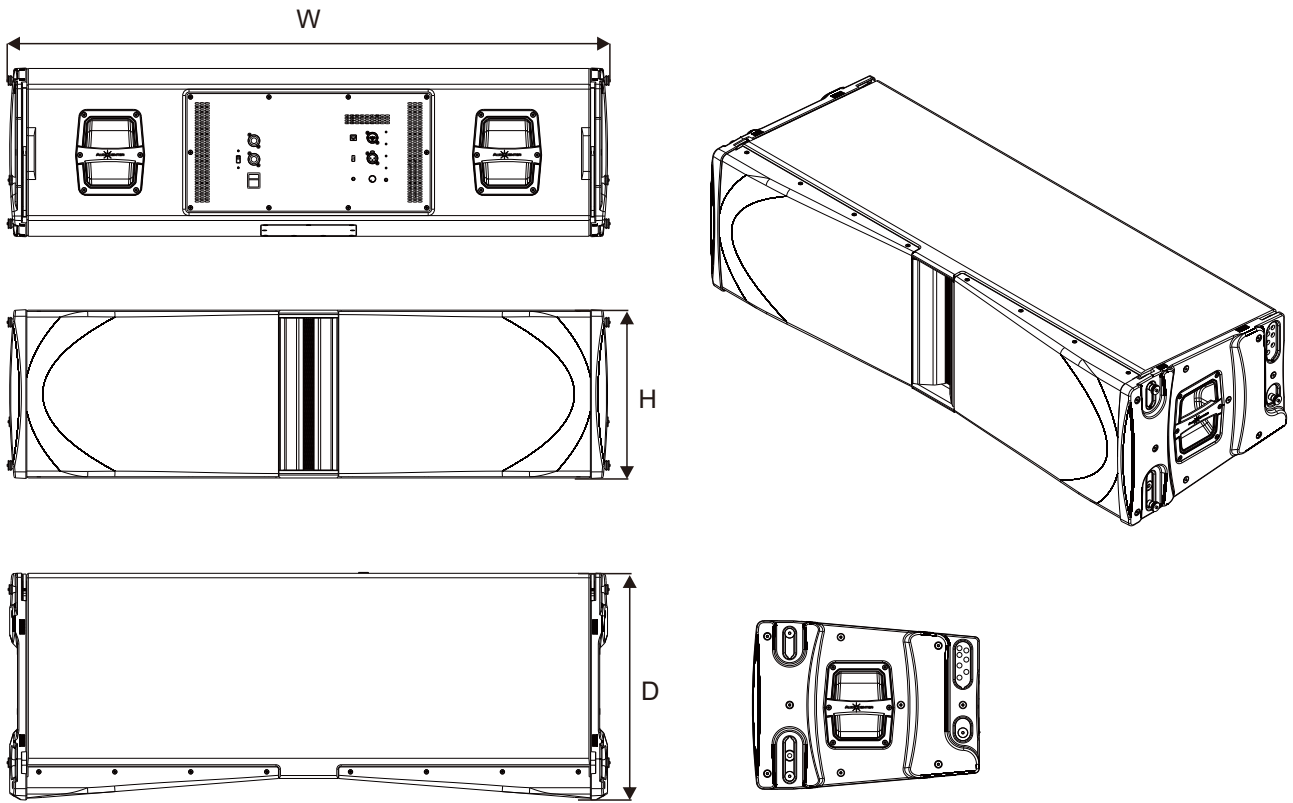

Dimension(WxHxD):1220x344x464mm

◆ Technical Specification

SPECIFICATIONS		AVANDA 212A	AVANDA 210A	AVANDA 28A
Frequency Response(-10dB)		60Hz-20kHz	67Hz-20kHz	70Hz-20kHz
Horizontal Coverage		90°		
Vertical Coverage		Splay angle dependent		
Maximum Calculated SPL/1M	Continuous	136dB	132dB	127dB
	Program	139dB	135dB	130dB
	Peak	142dB	138dB	133dB
Drivers	HF	Customized Neodymium driver, 2x3" voice coil, 1.4" exit		Customized Neodymium driver, 1x3" voice coil, 1.4" exit
	MF	Customized 4x6" driver, 1.75" voice coil	/	
	LF	Customized 2x12" driver, 3.0" voice coil	Customized 2x10" driver, 2.5" voice coil	Customized 2x 8" driver, 2.0" voice coil

DSP

Processor	96kHz signal sampling frequency, FIR filtering
Presets	4 Units, 8 Units, 12 Units

AMPLIFIER

Amplifier	Class D		
Power(RMS standards)	2600W	1600W	1000W
Peak Power	5200W	3200W	2000W
Frequency Response(1W 8Ω 2ch)	20Hz-20kHz(±0.5dB)		
Intermodulation Distortion (20Hz-20kHz, half power)	<0.05%		
Total Harmonic Distortion (20Hz-20kHz, half power)	<0.05%		
Cooling	Cooling with fans, air convection		
Protection	DC protection	√	
	Short circuit protection	√	
	Overheat protection	√	
	Output overload protection	√	
	Soft startup protection	√	
	Overvoltage protection	√	
	Undervoltage protection	√	
Signal Input/Output Connectors	Female XLR input, male XLR output		
Power Input Connectors	Power connector		
Power Output Connectors	Power connector		
AC Power Operating Range	100V-130V~ or 220V-240V~(±10%,50/60Hz)		
Power consumption(1/8 output power)	300W	142W	95W

CABINET

Cabinet Material	Multilayer baltic birch plywood		
Angle Adjustment	0°, 1°, 2°, 4°, 6°, 8°, 10°	0°, 1°, 2°, 4°, 6°, 8°, 10°, 12°	
Coating	Durable Polyurea Coating		
Cabinet Color	Black is the default color. Contact Audiocenter for customization		
Grille	Iron mesh		
Handles	2 side, 2 rear	2 side	
Optional Accessories	Frame for flying and ground stacking / Flightcase with 100mm wheels / Rain bag / Dolly		
Speaker Dimension(W×H×D)	1220×344×464mm	830×293×420mm	774×240×406mm
Carton Dimensions (W×H×D)	1322×568×443mm	936×526×393mm	868×501×346mm
Net Weight	67.0kg	39.0kg	24.0kg
Shipping Weight	70.0kg	42.0kg	27.0kg
Technical Support and After-sales Service	Global application support team, EASE GLL files available		

■ All content subject to change without notice. All rights reserved. AC - AVANDA - 202604

◆ Trouble Shooting

Symptom	Possible reasons	Solution
Power LED not light	Cable not connected correctly	Connect the cable correctly
No sound	Cable not connected correctly. Or too small gain.	Connect with input socket correctly. Adjust speaker output gain input bigger.
Feedback in the sound	Microphone is toward to speaker Sound is too high. Wrong preset used.	Keep speakers out of the microphone response area. Lower the output gain.
Sound Discrepancy from different speakers .	Different gain for different speakers Different presets for different speakers Subwoofers are out phase	Put the same gain for different speakers. Use the same presets for different speakers. Make the subs in phase
Sound distortion	Input volume is too big Output volume is too big	Reduce the input volume of the equipments Reduce the output gain of the speakers, make the Limiter LED light a bit If the sound still distorted while the volume is set to minimum, make the MIC/LINE switch to be LINE.
Microphone volume is too small	MIC/LINE switch is set at LINE	Set the MIC/LINE at MIC
Not enough SPL while full range speakers used together with subs	Subs might be out of phase	Adjust the phase of subs
The light signal is on, there is a signal output, but the speaker does not sound	Maybe the volume knob is set to the minimum, Closing the volume	Slightly increase the volume knob

★ Please consult distributor if there are still problems



Dynamic Audio Solutions